



## **LP & LPR SERIES**



### **MOBILE AIR COOLED**

# **OIL COOLERS**

**12 volt & 24 volt DC motor**

- Mobile design.
- Custom designs to fit your needs.
- Operating temperature of 400° F and pressure of 300PSI.
- Standard NPT or SAE connections.
- Cools: Fluid power systems, lubrication systems, hydraulic presses, gear drives, torque convertors, machine tools, etc...

# LP & LPR Series *selection*

## SIZING

To properly size a DC fan drive air-cooled oil cooler for mobile equipment, you should first determine some basic parameters associated with the system.

## HEAT LOAD

In many instances the heat load must be determined by using a "total potential" method. This total potential or horse power method is the most common method, and is the simplest way to determine basic heat rejection requirements for mobile hydraulic systems. The total potential is equal to the maximum operating flow and pressure that are generated by the system under full load. To determine the total potential (HP) use the following formula.

$$HP = [ \text{System Pressure (PSI)} \times \text{System Flow (GPM)} ] / 1714$$

Example:

$$HP = (3000 \text{ PSI} \times 6.0 \text{ GPM}) / 1714 = 10.5 \text{ HP or the total input potential}$$

To determine the system heat load in BTU / HR we must use a percentage (*v*) of the system potential HP. The factor (*v*) can be calculated by adding up the actual inefficiencies of a system; however, for most applications a (*v*) value of 25% - 30% can be used.

Example:

$$10.5 \text{ HP} \times .25 = 2.63 \text{ HP heat}$$

To convert the horsepower of heat into BTU/HR use the formula below:

$$HP \times 2542 = \text{BTU/HR}$$

Example:

$$2.63 \text{ HP} \times 2542 = 6,681 \text{ BTU/HR}$$

## Applying into a return line

For most open loop systems with a vane or gear type fixed delivery pumps. To calculate the Fs value required when applying the air/oil cooler into a return line use the formula below.

$$F_s = \frac{\text{BTU/HR} \times C_v}{T - t_{\text{ambient}}} \quad F_s = \frac{6,681 \times 1.13}{140^\circ\text{F} - 100^\circ\text{F}} = 189$$

T = Desired system oil temperature leaving the cooler °F (140°F)

t<sub>ambient</sub> = Ambient air temperature entering the cooler °F

Cv = Correction factor for oil viscosity. Example: ISO68 oil @ 150°F = 1.13 (see chart)

## APPLYING INTO A CASE DRAIN LINE

In circumstances where the system is a closed loop or when return line flow

is not available, the case drain flow can be utilized to help cool the system. However, in many instances, the case drain flow alone will not be enough to reject all of the heat generated by the system. Case drain lines should not be treated as a normal return line since the pressure drop allowable usually can vary from 12 - 10 PSI max. Check with your pump manufacturer for the appropriate pressure drop tolerance before applying any cooler. To size the system for case flow or case flow plus any additional cooling loops, please use the following method.

Formula

T = System temperature entering

$$T_{c_{\text{exit}}} = \{ T - [ Q / (\text{case flow gpm} \times 210) ] \}$$

Example

$$T_{c_{\text{exit}}} = \{ 150 - [ 6,681 / (4 \times 210) ] \} = 142$$

T<sub>c<sub>exit</sub></sub> = The corrected temperature of the oil exiting the cooler.

$$F_s = \frac{Q \times C_v}{T_{c_{\text{exit}}} - t_{\text{ambient}}} = \frac{6,681 \times 1.13}{142 - 100} = 180 F_s$$

## SELECTION

To select a model, locate the flow rate (GPM) at the bottom of the flow vs Fs graph. Proceed upward until the GPM intersects with the calculated Fs. The curve closest above the intersection point will meet these conditions.

Examples:

Return Line	Case Line
Fs = 189	Fs = 180
GPM = 6 "return line flow"	GPM = 4
Model = LP - 300	Model = LP - 300

## PRESSURE DROP

Determine the oil pressure drop from the curves as indicated. For viscosities other than 50 ssu, multiply the actual indicated pressure drop (psi) for your GPM by the value in the pressure differential curve for your viscosity value.

Examples:	<u>GPM = 6</u>	<u>GPM = 4</u>
Indicated pressure drop	.2 PSI	.1 PSI
Cp correction factor for ISO 68 oil @ 150°F	.213	.113

Average Liquid Temperature	Cv VISCOSITY CORRECTION FACTORS																
	SAE 5	SAE 10	SAE 20	SAE 30	SAE 40	ISO 22	ISO 32	ISO 46	ISO 68	ISO 100	ISO 150	ISO 220	ISO 320	MIL-L-7808	POLYGLYCOL	PHOSPHATE ESTER	50% ETHYLENE GLYCOL & WATER
100	1.11	1.15	1.25	1.38	1.45	1.08	1.14	1.18	1.26	1.37	1.43	1.56	1.84	1.19	0.92	0.83	0.85
110	1.09	1.12	1.20	1.32	1.40	1.06	1.13	1.16	1.25	1.31	1.39	1.48	1.67	1.14	0.89	0.80	0.84
120	1.06	1.10	1.17	1.27	1.35	1.04	1.11	1.14	1.20	1.27	1.35	1.40	1.53	1.09	0.88	0.79	0.84
130	1.04	1.08	1.13	1.24	1.29	1.03	1.09	1.13	1.17	1.24	1.30	1.34	1.44	1.05	0.85	0.77	0.83
140	1.03	1.05	1.11	1.19	1.25	1.02	1.08	1.10	1.16	1.20	1.26	1.30	1.39	1.03	0.84	0.76	0.82
150	1.01	1.04	1.09	1.16	1.22	1.02	1.06	1.09	1.13	1.17	1.22	1.27	1.33	1.01	0.83	0.74	0.82
200	0.98	0.99	1.01	1.04	1.07	0.98	0.99	1.00	1.01	1.02	1.08	1.09	1.14	0.98	0.79	0.71	0.80
250	0.95	0.96	0.97	0.98	0.99	0.95	0.96	0.96	0.96	0.97	0.99	1.01	1.02	0.97	0.76	0.69	0.79

Average Liquid Temperature	Cp PRESSURE DROP CORRECTION FACTORS																
	SAE 5	SAE 10	SAE 20	SAE 30	SAE 40	ISO 22	ISO 32	ISO 46	ISO 68	ISO 100	ISO 150	ISO 220	ISO 320	MIL-L-7808	POLYGLYCOL	PHOSPHATE ESTER	50% ETHYLENE GLYCOL & WATER
100	2.00	2.40	4.40	6.40	8.80	1.07	1.53	1.82	2.54	4.19	6.44	9.38	13.56	1.26	3.00	3.50	0.730
110	1.70	2.10	3.60	5.10	6.70	1.04	1.45	1.72	2.35	3.73	5.70	8.33	11.63	1.20	2.40	2.90	0.720
120	1.50	1.80	3.00	4.20	5.60	1.02	1.38	1.60	2.15	3.26	4.91	7.23	9.73	1.14	2.10	2.50	0.709
130	1.40	1.60	2.60	3.40	4.50	0.99	1.30	1.49	1.94	2.80	4.14	6.19	7.80	1.08	1.90	2.20	0.698
140	1.30	1.50	2.23	2.90	3.70	0.97	1.23	1.38	1.75	2.38	3.47	5.20	6.11	1.03	1.90	2.00	0.686
150	1.20	1.30	1.90	2.50	3.10	0.95	1.17	1.30	1.61	2.04	2.90	4.35	4.77	0.98	1.70	1.90	0.676
200	0.93	0.96	1.20	1.40	1.60	0.89	0.99	1.08	1.18	1.33	1.59	1.74	1.95	0.90	1.20	1.30	0.635
250	0.81	0.82	0.92	0.97	1.05	0.85	0.93	0.96	1.03	1.11	1.21	1.22	1.23	0.83	1.00	1.05	0.556

note: AIHTI reserves the right to make reasonable design changes without notice.

# LP & LPR Series motor data

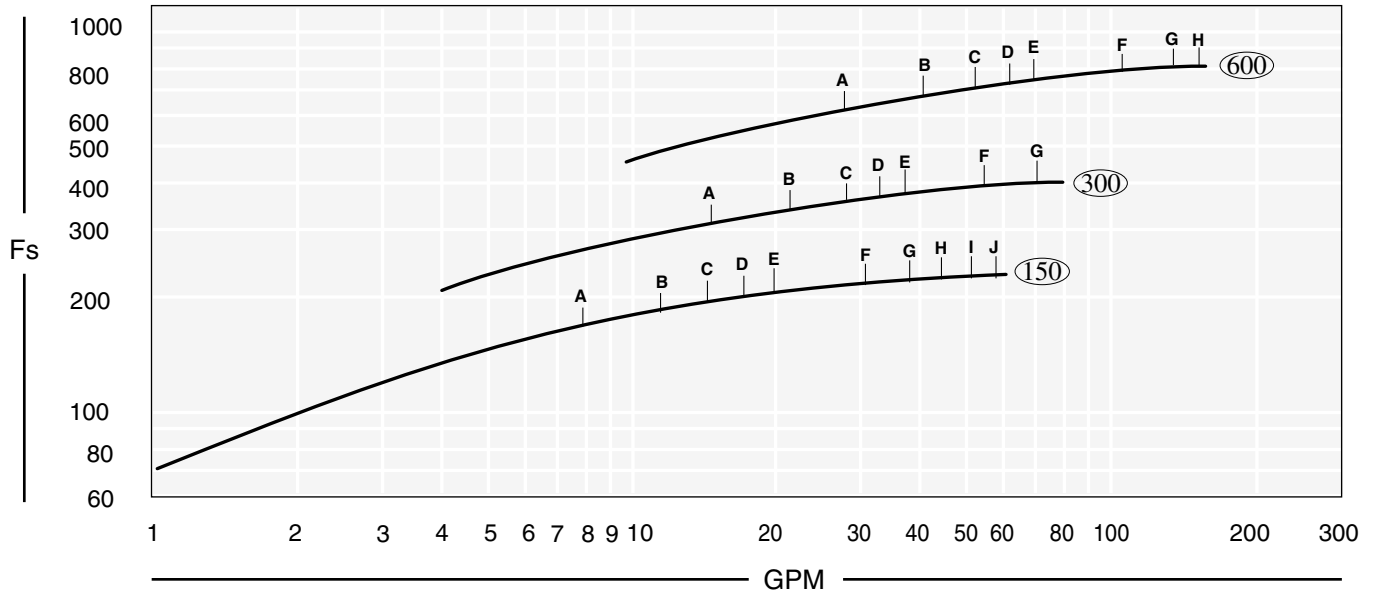

**PERFORMANCE CALCULATION**

$$F_s = \frac{\text{Horsepower to be removed (HP)} \times 2545 \times C_v}{\text{°F (Oil Leaving* - Ambient Air Entering)}} = \frac{\text{BTU}}{\text{hr °F}}$$

\*Represents desired fluid leaving the cooler.

**OIL PRESSURE DROP (PSI) CODE**

A = 1 PSI	D = 4 PSI	G = 15 PSI	J = 30 PSI
B = 2 PSI	E = 5 PSI	H = 20 PSI	
C = 3 PSI	F = 10 PSI	I = 25 PSI	

## LP MOTOR DATA

Model	Volts	FLA Per Motor	RPM	Total CFM
LP - 150	12 / 24	9.0 / 4.5	2000	950
LPR - 150	12 / 24	9.0 / 4.5	2000	950
LP - 300	12 / 24	9.0 / 4.5	2000	950
LPR - 300	12 / 24	9.0 / 4.5	2000	950
LP - 600	12 / 24	9.0 / 4.5	2000	1900
LPR - 600	12 / 24	9.0 / 4.5	2000	1900

## STANDARD CONSTRUCTION MATERIALS

Standard Construction Materials			
Tubes	Copper	Mount. bracket	Steel
Fins	Aluminum	Cabinet	Steel
Turbulators	Steel	Fan Blade	Aluminum
Manifold	Steel		

Standard Unit Ratings	
Operating Pressure	300 psig
Operating Temp.	400 °F

## PIPING HOOK-UP

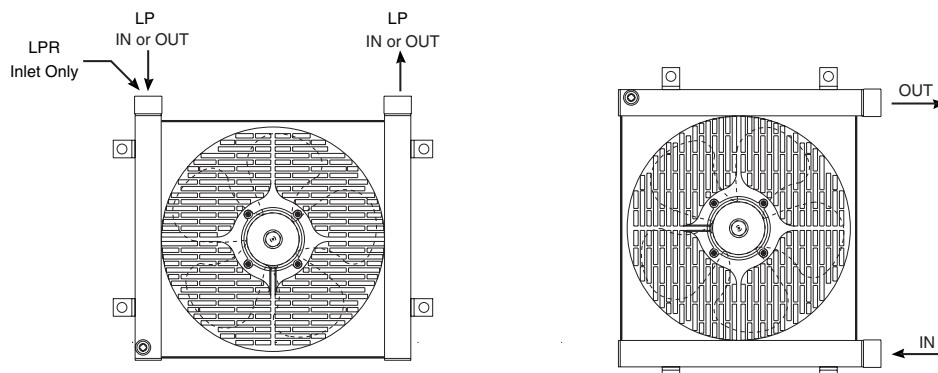

note: AIHTI reserves the right to make reasonable design changes without notice.

# LP & LPR Series *dimensions*

## MODELS LP-150 and LP-300

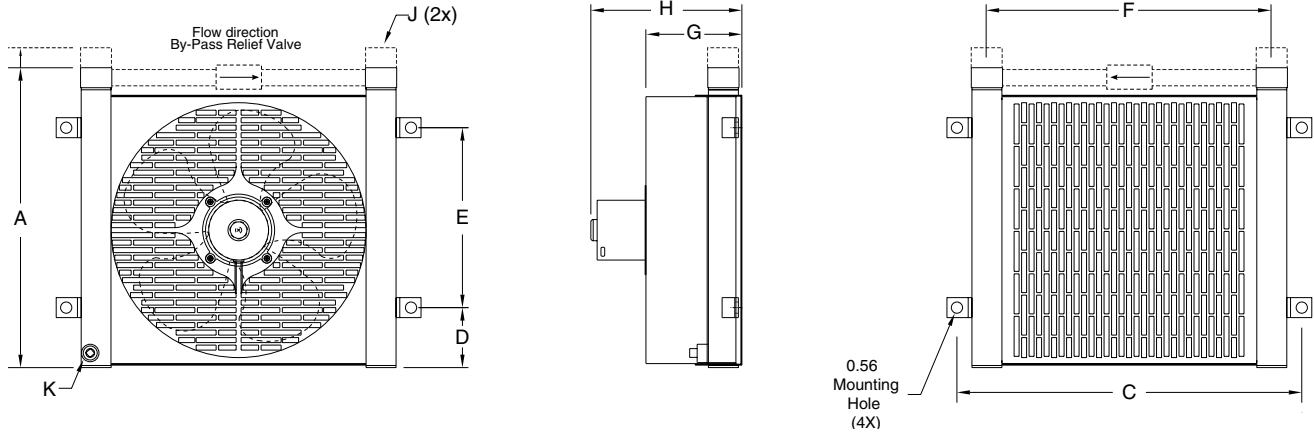

## MODEL LP-600

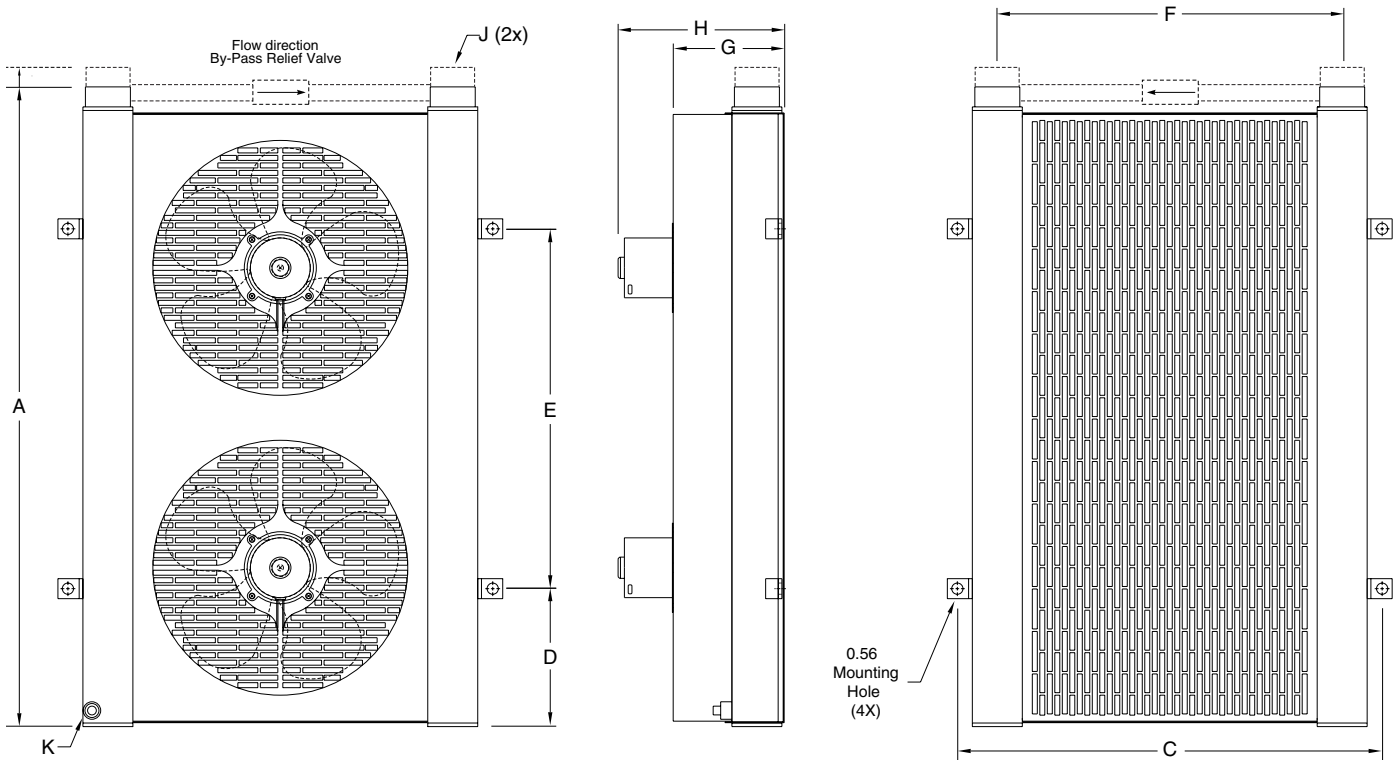

## COMMON DIMENSIONS & WEIGHTS

Model	A	C	D	E	F	G	H	J NPT	J SAE	K NPT	Weight	Model
LP-150	15.00	17.25	3.00	9.00	14.25	4.90	7.68	1.00	#16	.375	28	LP-150
LPR-150	17.50										31	LPR-150
LP-300	17.00	3.13	17.25		5.40	8.18	1.50	#24	37		LP-300	
LPR-300	19.50			40					LPR-300			
LP-600	32.00	21.25	6.90	18.00	73	LPR-600						
LPR-600	34.50											

## EXAMPLE OF A MODEL

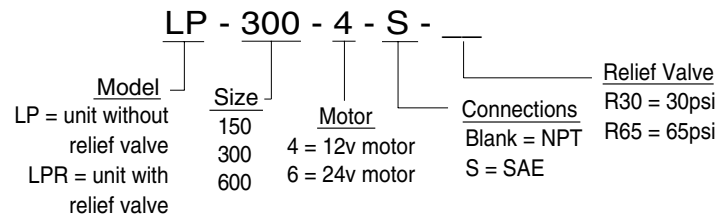

note: AIHTI reserves the right to make reasonable design changes without notice.

# LP & LPR Series *installation & maintenance*

## Receiving / Installation

a) Inspect unit for any shipping damage before uncrating. Indicate all damages to the trucking firms' delivery person and mark it on the receiving bill before accepting the freight. Make sure that the core and fan are not damaged. Rotate the fan blade to make sure that it moves freely. *Since the warranty is based upon the unit date code located on the model identification tag, removal or manipulation of the identification tag will void the manufacturers warranty.*

c) Standard Enamel Coating: American Industrial provides its standard products with a normal base coat of oil base air cure enamel paint. The enamel paint is applied as a temporary protective and esthetic coating prior to shipment. While the standard enamel coating is durable, American Industrial does not warranty it as a long-term finish coating. It is strongly suggested that a more durable final coating be applied after installation or prior to long-term storage in a corrosive environment to cover any accidental scratches, enhance esthetics, and further prevent corrosion. It is the responsibility of the customer to provide regular maintenance against chips, scratches, etc... and regular touch up maintenance must be provided for long-term benefits and corrosion prevention.

d) Special Coatings: American Industrial offers as customer options, Air-Dry Epoxy, and Heresite (Air-Dry Phenolic) coatings at additional cost. American Industrial offers special coatings upon request, however American Industrial does not warrantee coatings to be a permanent solution for any equipment against corrosion. It is the responsibility of the customer to provide regular maintenance against chips, scratches, etc... and regular touch up maintenance must be provided for long-term benefits and corrosion prevention.

e) American Industrial recommends that the equipment supplied should be installed by qualified personnel who have solid understanding of system design, pressure and temperature ratings, and piping assembly. Verify the service conditions of the system prior to applying any air cooled heat exchanger series cooler. If the system pressure or temperature does not fall within the parameters on model rating tag located on the heat exchanger, contact our factory prior to installation or operation.

g) Heat exchanger should be securely fastened using the mounting foot brackets (included). All mounting holes should be used to secure unit into place.

h) Connections should be made in configurations exactly as indicated in the "piping hook up" illustration. The process flow entering the "Fluid IN" port and exiting the "Fluid OUT" port eliminates air pockets and assures that the unit will stay completely flooded. Flexible hose can be applied to reduce the risk of core failure due to thermal expansion or system vibration. Piping alignment and support is required for hoses longer than four feet in length and for piping exerting more than 10 lbs of dynamic force. It is recommended that filtration be located ahead of the heat exchanger to prevent excessive backpressure and clogging.

i) With respect to the heat exchangers nozzle size, flow line sizes should be sized to handle the appropriate flow rate and system pressure drop requirements, normally flow line rates of about 8-12 feet per second and inlet pressure less than 100psig are experienced. If the flow line size is larger than the heat exchanger nozzle size, additional pressure loss beyond the published pressure loss data may occur.

j) Electric motors should be connected only to supply source of the same characteristics as indicated on the electric motor information plate. Prior to starting, verify that the motor and fan spin freely without obstruction. Check carefully that the fan turns in the correct rotation direction (normally counter clockwise) from the motor side (fan direction arrow). Failure to operate the fan in the proper direction could reduce performance or cause serious damage to the heat exchanger or other components.

k) Solely at the request of customers, American Industrial provides direct acting internal inlet port to outlet port bypass relief valves as an additional safe guard against excessive flow and over pressurization of the heat exchanger. American Industrial purchases and applies high quality hydraulic system cartridge valves and components made available for hydraulic system use. However, American Industrial does not specify, recommend, suggest, guarantee, or warrantee the internal relief valve or its performance to safe guard the heat exchanger from damage or prevent failure due to excessive flow or over pressurization. It is the ultimately the sole responsibility of the customer/user to verify with the original equipment manufacture all conditions associated with applying an additional system relief valve prior to application.

## Maintenance

Regular maintenance intervals based upon the surrounding and operational conditions should be maintained to verify equipment performance and to prevent premature component failure. Since some of the components such as, motors, fans, etc... are not manufactured by American Industrial, maintenance requirements provided by the manufacture must be followed.

a) Inspect the entire heat exchanger and motor/fan assembly for loosened bolts, loose connections, broken components, rust spots, corrosion, fin/coil clogging, or external leakage. Make immediate repairs to all affected areas prior to restarting and operating the heat exchanger or its components.

b) Heat exchangers operating in oily or dusty environments will often need to have the coil cooling fins cleaned. Oily or clogged fins should be cleaned by carefully brushing the fins and tubes with water or a non-aggressive degreasing agent mixture (*Note: Cleaning agents that are not compatible with copper, brass, aluminum, steel or stainless steel should not be used*). A compressed air or a water stream can be used to dislodge dirt and clean the coil further. Any external dirt or oil on the electric motor and fan assembly should be removed. *Caution: Be sure to disconnect the electric motor from its power source prior to doing any maintenance.*

c) In most cases it is not necessary to internally flush the coil. In circumstances where the coil has become plugged or has a substantial buildup of material, flushing the coil with water or a solvent may be done. Flushing solvents should be non-aggressive suitable for the materials of construction. Serviceable Core® models can be disassembled and inspected or cleaned if required.

e) Fan blades should be cleaned and inspected for tightness during the regular maintenance schedule when handling a fan blade care must be given to avoid bending or striking any of the blades. Fan blades are factory balanced and will not operate properly if damaged or unbalanced. Damaged fan blades can cause excessive vibration and severe damage to the heat exchanger or drive motor. Replace any damaged fan with an American industrial suggested replacement.

f) Air cooled exchanger cabinets are constructed using 7ga. through 18ga. steel that may be bent back into position if damaged. Parts that are not repairable can be purchased through American Industrial.

g) Coil fins that become flattened can be combed back into position. This process may require removal of the coil from the cabinet.

h) It is not advisable to attempt repairs to brazed joints of a brazed construction coil unless it will be done by an expert in silver solder brazing. Brazed coils are heated uniformly during the original manufacturing process to prevent weak zones from occurring. Uncontrolled reheating of the coil may result in weakening of the tube joints surrounding the repair area. In many instances brazed units that are repaired will not hold up as well to the rigors of the system as will a new coil. American Industrial will not warranty or be responsible for any repairs done by unauthorized sources. Manipulation in any way other than normal application will void the manufactures warranty.