



ACA SERIES



AIR COOLED

AFTERCoolERS

For Compressed Gas or Vapor

- Computer Selection.
- Low pressure drop available.
- Standard ports NPT, optional ANSI flange.
- Operating temperature of 400° F & pressure of 150PSI.
- Custom designs to fit your needs.
- Cools: Air, Compressors, Blowers, Steam vapors, Pneumatic systems, Vapor recovery systems etc...

ACA Series *construction*

ACA - 3181 through ACA - 4362



Brazed Core Construction

Air coolers are an essential part of any compressed air system, by cooling the air, and condensing water vapor into a liquid state for removal. When air is compressed, the compression induces heat into both the air and the water entrained in the air.

The American Industrial ACA series heat exchanger cools air with air, making it a simple inexpensive way to cool when compared to other water-cooled or refrigerant cooled systems. The unique compact brazed fin/tube design provides efficient cooling and low maintenance under the warmest environmental conditions. By using an ACA series air-cooled after cooler, machine tools will receive cooler dryer air, provide longer trouble free life, experience less down time, and be cost effective to operate on a continuous basis.

SUPERIOR COOLING FINNS

Copper tubes are mechanically bonded to highly efficient aluminum cooling fins. Die-formed fin collars provide a durable precision fit for maximum heat transfer. Custom fin design forces air to become turbulent and carry heat away more efficiently than old flat fin designs.

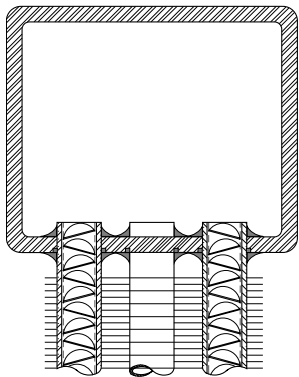

TANKS

State-of-the-art high temperature brazing method insures permanent bond and positive contact of tube to manifold, eliminating leaks and providing maximum service life.

CONSTRUCTION MATERIALS & RATINGS

Standard Construction Materials		Standard Unit Ratings	
Tubes	Copper	Operating Pressure	150 psig
Fins	Aluminum	Operating Temperature	400 °F
Cabinet & Pipes	Steel	Consult factory for optional materials and ratings.	
Fan Guard	Zinc Plated Steel		
Manifolds	Steel		

note: AIHTI reserves the right to make reasonable design changes without notice.

ACA - 6301 through ACA 6602



Serviceable Core® Construction

Air coolers are an essential part of any compressed air system, by cooling the air, and condensing water vapor into a liquid state for removal. When air is compressed, the compression induces heat into both the air and the water entrained in the air. The American Industrial ACA series heat exchanger cools air with air, making it a simple inexpensive way to cool when compared to other water-cooled or refrigerant cooled systems. The unique compact *serviceable core®* design provides efficient cooling and low maintenance under the warmest environmental conditions. By using an ACA series air-cooled after cooler, machine tools will receive cooler dryer air, provide longer trouble free life, experience less down time, and be cost effective to operate on a continuous basis.

SERVICEABLE CORE®

Core covers disassemble for easy access and cleaning. Repairable design for applications that require limited down time or in the event of a mishap requiring repair. Roller expanded tube to tube-sheet joint. 100% mechanical bond. Positive gasket seal is field replaceable for field maintenance or repair.

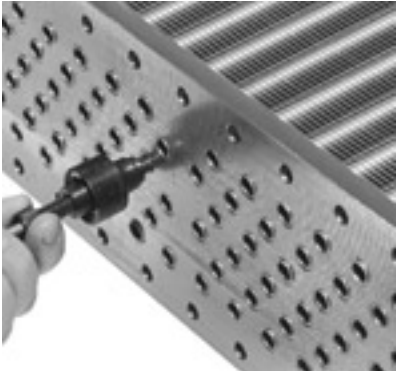
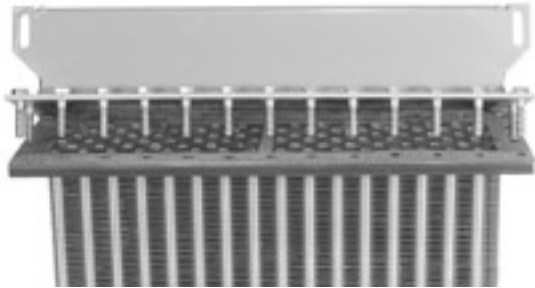

SUPERIOR COOLING FINNS

Copper tubes are mechanically bonded to highly efficient aluminum cooling fins. Die-formed fin collars provide a durable precision fit for maximum heat transfer. Custom fin design forces air to become turbulent and carry heat away more efficiently than old flat fin designs.

CONSTRUCTION MATERIALS & RATINGS

Standard Construction Materials		Standard Unit Ratings	
Tubes	Copper	Operating Pressure	150 psig
Fins	Aluminum	Operating Temperature	400 °F
Cabinet & Pipes	Steel	Consult factory for optional materials and ratings.	
Fan Guard	Zinc Plated Steel		
Manifolds	Steel		

ACA Series selection

Compressed Air

Normally air compressors have airflow rates based upon the horsepower. Rotary Screw compressors normally discharge air at 180 °f - 200 °f, prior to after-cooling. Reciprocating compressors normally discharge air at 250 °f - 275 °f, prior to after-cooling. Compressors are rated in CFM or cubic feet per minute of free air at inlet conditions. For practical purpose we will use sea level at 68 °f and 36% relative humidity as a norm. Altitude, differing ambient conditions with respect to temperature and humidity will all affect heat exchanger performance to a degree. Moisture content in air actually increases the Btu/hr load requirement for cooling air by adding an additional condensing load to the gas load requirement. As air rapidly cools, moisture in the compressed air stream will condense and separate into droplets, the more humidity present the more condensation will occur.

Sizing

The performance curves provided are for air. However, gases other than air may be applied to this cooler with respect to compatibility by applying a correction factor. Please take time to check the operating specifications thoroughly for material compatibility, pressure, and size before applying an American Industrial heat exchanger into your system.

Terms

Approach Temperature is the desired outlet temperature of the compressed gas minus the inlet ambient air temperature of the external air flowing over the coil.

SCFM (Standard Cubic Feet per Minute)

A cubic foot of air at 68 °f, 14.696 psia, & 36% relative humidity, per minute.

CFM (Cubic Feet per Minute)

Air at inlet atmospheric conditions.

ACFM (Actual Cubic Feet per Minute)

Air at current pressure, temperature, & humidity conditions without reference to a standard.

To Determine the Heat Load

If the heat load (Btu/hr) is unknown a value can be calculated based upon system operational requirements. To properly calculate the heat load (Btu/hr) to be rejected, several items must be known with certainty (see below).

- Flow rate SCFM (standard cubic feet pr minute)
- Type of gas and its makeup.
- System inlet pressure to the heat exchanger.
- Ambient temperature where the heat exchanger will be located (hottest condition).
- Temperature of the gas at the heat exchanger inlet.
- Temperature of the gas desired at heat exchanger outlet.
- Maximum acceptable pressure loss or cooled gas.

Using The Chart

American Industrial has created a quick reference chart for selecting ACA heat exchangers for Rotary Screw compressors (see page 214) [This chart offers basic information based upon compressor horsepower and average airflow rates. To properly use the chart, select the compressor horsepower at the left or the air flow rate. Next select the approach to ambient that is desired. Where the two columns intersect is shown the proper ACA model number.]

Using The Graphs

American Industrial provides performance graphs for ease of model selection. The following calculation examples (page 213), illustrate formulas to determine model selection sizes. It should be noted that there are some assumptions made when applying the basic principles for calculation in the formula. Altitude, humidity, materials, pressures, etc... all contribute to the final selection. Contact American Industrial for more detailed calculation.

Selection

The selection process is important, many considerations should be made when selecting a heat exchanger. Once the proper Fs requirement is calculated, it is time to apply the data to the graph and make a selection.

1) Find the Flow rate in SCFM located at the bottom of the graph. Follow the graph line up until it matches the calculated Fs from your calculations. If the point falls just above one of the model graphed lines, select the next larger size. If the point is on a line select it as your choice.

2) Check carefully the pressure differential. Units with operating pressures from 70+ psig will have no greater than 2.0 psid within the published flow range. For lower inlet pressure see the pressure drop curves for more detail.

3) Calculate a Nozzle size using the nozzle size calculation to verify your selection has the proper port sizes for your required inlet pressure.

Formula: Nozzle Calculation

$$\text{Nozzle Size} = \sqrt{\frac{(\text{SCFM} \times 4.512) \times 144}{(270,000 \times d) \times .7854}}$$

All numbers in equation are constants except for SCFM and (d) "density".

Example:

Flow rate = 200 SCFM

Pressure = 15 psig

Density = (d) from Compressed Air Density Graph

$$\sqrt{\frac{(200 \times 4.512) \times 144}{(270,000 \times .14) \times .7854}} = 2.09" \text{ or } (2" \text{ Nozzle})$$

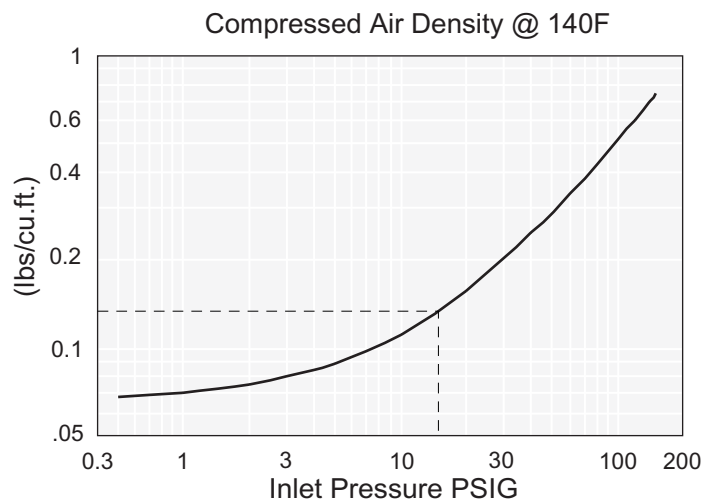

Examples: (Note: All air flow rates must be converted to SCFM)

Application 1 Air Rotary Screw Compressor

Determine the heat load "Q" =Btu/hr

$$Q = [\text{SCFM} \times \text{CF} \times (T_1 - T_2)] \text{ or } [350 \times 1.13 \times 105^\circ] = 41,528 \text{ Btu/hr}$$

T₁ = Inlet gas temperature: 200°F

T₂ = Outlet gas temperature: Ambient + 10°F = (95°F)

T_a = Ambient temperature: 85°F

Airflow rate: 350 SCFM

PSIG = Operating Pressure 100 psig

CF = Correction factor: 1.13

S = Specific gravity with air being 1.0

C = Specific heat (Btu/Lb °f): .25

Model Selection - ACA-4362

Determine the Fs = $\frac{\text{Btu/hr}}{T_2 - T_a}$ or $\frac{41,528}{10} =$

4,153 Fs Refer to graph example on page 215

$$\text{CF} = (.0753 \times S \times C \times 60) \text{ or } (.0753 \times 1.0 \times .25 \times 60) = 1.13$$

$$\sqrt{\frac{[(350 \times 4.512) \times 144]}{(270,000 \times .50)}} = 1.46" \text{ or } (1.5" \text{ minimum nozzle})$$

Application 2 Methane Gas

Determine the heat load "Q" = Btu/hr

$$Q = [\text{SCFM} \times \text{CF} \times (T_1 - T_2)] \text{ or } [500 \times 1.428 \times 210^\circ] = 149,940 \text{ Btu/hr}$$

T₁ = Inlet gas temperature: 300°F

T₂ = Outlet gas temperature: 90°F

T_a = Ambient temperature: 60°F

Gas flow rate: 500 SCFM

PSIG = Operating pressure: 150 psig

CF = Correction factor: 1.428

S = Specific gravity with air being 1.0: .55

C = Specific heat (Btu/Lb °f)

Model Selection - ACA-6421

Determine the Fs = $\frac{\text{Btu/hr}}{T_2 - T_a}$ or $\frac{149,940}{30} =$

4,998 Fs Refer to graph example on page 215

$$\text{CF} = (.0753 \times S \times C \times 60) \text{ or } (.0753 \times .55 \times .575 \times 60) = 1.428$$

$$\sqrt{\frac{[(500 \times 4.512) \times 144]}{(270,000 \times .74)}} = 1.44" \text{ or } (1.5" \text{ minimum nozzle})$$

Application 3 Low Pressure Blower

Determine the heat load "Q" = Btu/hr

$$Q = [\text{SCFM} \times \text{CF} \times (T_1 - T_2)] \text{ or } [76 \times 1.13 \times 150^\circ] = 12,882 \text{ Btu/hr}$$

T₁ = Inlet gas temperature: 250°F

T₂ = Outlet gas temperature: 100°F

T_a = Ambient temperature: 90°F

CF = Correction Factor: 1.13

PSIG = Operating pressure: 2 psig

Airflow rate: 90 ACFM

S = Specific gravity with air being 1.0

C = Specific heat (Btu/lb °f): .25

ΔP = 5" water column or less (example pg. 220)

Model Selection - ACA-3302

Determine the Fs = $\frac{\text{Btu/hr}}{T_2 - T_a}$ or $\frac{12,882}{10} =$

1,288 Fs Refer to graph example on page 215

To Convert

$$\text{ACFM to SCFM} = \frac{\text{ACFM} \times (\text{PSIG} + 14.7) \times 528}{(T_1 + 460) \times 14.7} = \frac{90 \times 16.7 \times 528}{710 \times 14.7} = 76 \text{ SCFM}$$

$$\sqrt{\frac{[(76 \times 4.512) \times 144]}{(270,000 \times .075)}} = 1.76" \text{ or } (2.0" \text{ minimum nozzle})$$

Pressure Drop (see page 220 for graphs)

Since gas is compressible the density of the gas changes from one temperature or pressure to the next. While the mass flow rate may not change, the pressure differential across the heat exchanger will change dramatically from high (70-125 psig) to low (1-5 psig) pressure. A low pressure condition requires larger carrying lines to move flow than does the same gas rate under a higher pressure. At lower pressures the differential pressure across the heat exchanger can be quite high compared to the same flow rate at a higher pressure. For that reason it is suggested that the pressure differential graphs on page 220 be consulted prior to making your final selection.

The ACA series heat exchanger is designed to be easily modified to accept larger port sizes in the event your system pressure requires larger nozzles. Consult our engineering department for more exacting information regarding pressure differential issues.

ACA Series selection

ROTARY SCREW COMPRESSORS (200°F @ 125 PSI & 36% relative humidity)

Compressor Horse Power (HP)	Average Air Discharge Cubic feet per minute (SCFM)	Model Size Selection			
		*Approach Temperature °F ($T_2 - T_a$)			
		5°F	10°F	15°F	20°F
15	60	ACA - 3302	ACA - 3242	ACA - 3242	ACA - 3182
20	80	ACA - 3302	ACA - 3242	ACA - 3242	ACA - 3182
30	130	ACA - 3362	ACA - 3302	ACA - 3242	ACA - 3242
40	165	ACA - 3362	ACA - 3302	ACA - 3302	ACA - 3242
60	250	ACA - 4362	ACA - 3362	ACA - 3302	ACA - 3302
75	350	ACA - 6362	ACA - 4362	ACA - 3362	ACA - 3302
100	470	ACA - 6362	ACA - 6362	ACA - 3362	ACA - 3362
125	590	ACA - 6422	ACA - 6362	ACA - 4362	ACA - 3362
150	710	ACA - 6422	ACA - 6362	ACA - 6362	ACA - 4362
200	945	ACA - 6482	ACA - 6422	ACA - 6362	ACA - 6362
250	1160	ACA - 6482	ACA - 6422	ACA - 6362	ACA - 6362
300	1450	ACA - 6542	ACA - 6482	ACA - 6422	ACA - 6362
350	1630	ACA - 6542	ACA - 6482	ACA - 6422	ACA - 6362
400	1830	ACA - 6602	ACA - 6482	ACA - 6422	ACA - 6422
500	2150	ACA - 6602	ACA - 6542	ACA - 6482	ACA - 6422

*Approach Temperature

the desired outlet temperature of the compressed gas minus the inlet ambient air temperature of the external air flowing over the coil.

T_2 - Outlet gas temperature

T_a - Ambient temperature

Example of a model:

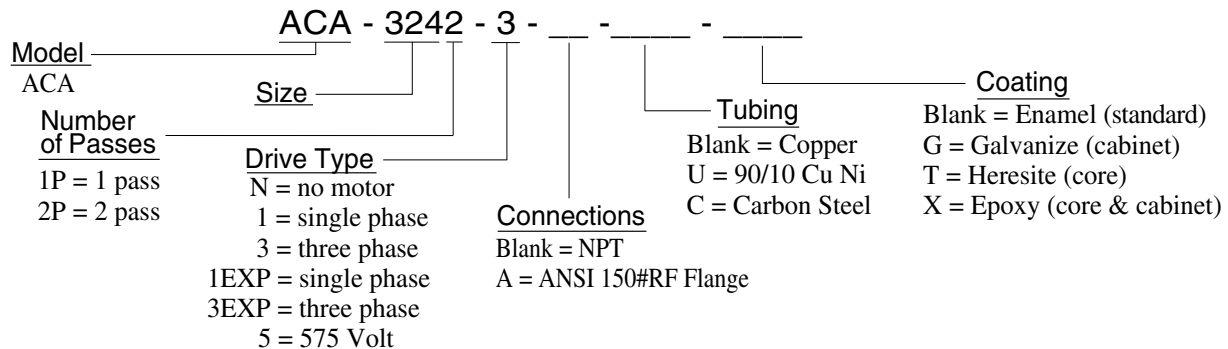

Using the performance graphs (page 215)

The Flow vs. F_s graph is calculated based upon SCFM units.

To convert volumetric Actual Cubic Feet per Minute (ACFM) into Standard Cubic Feet per Minute (SCFM) see page 213 application 3.

To select a model, locate the flow rate in SCFM located at the bottom of the graph. Proceed upward on the graph until the SCFM flow rate intersects with the calculated

F_s . The curve closest, on or above the intersection point is the proper selection.

Using the one pass graph or two-pass graph depends upon pressure differential, flow, and performance requirements. The actual surface area for one or two pass units is the same. However, the airflow velocity in the tubes increases with the number of passes giving slightly higher pressure differentials and better cooling performance.

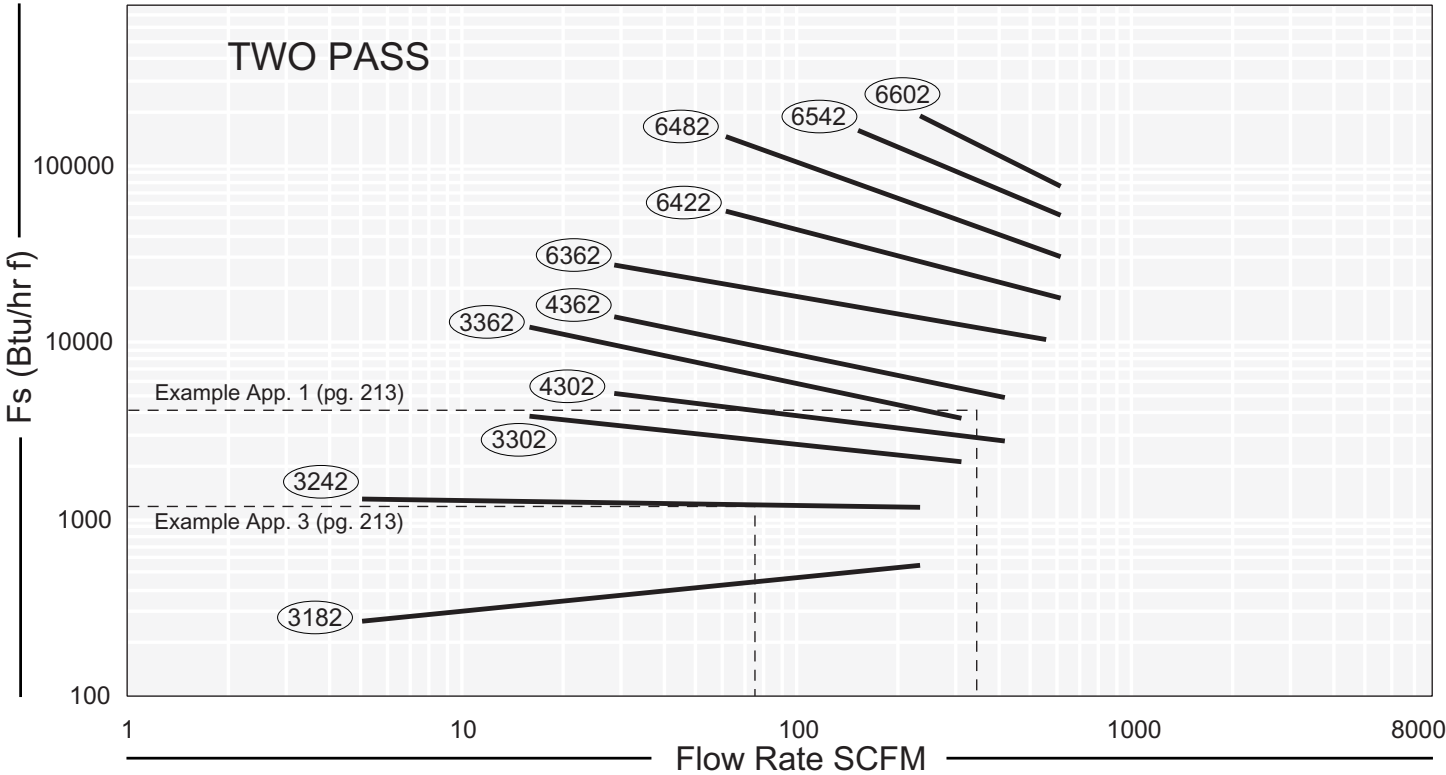
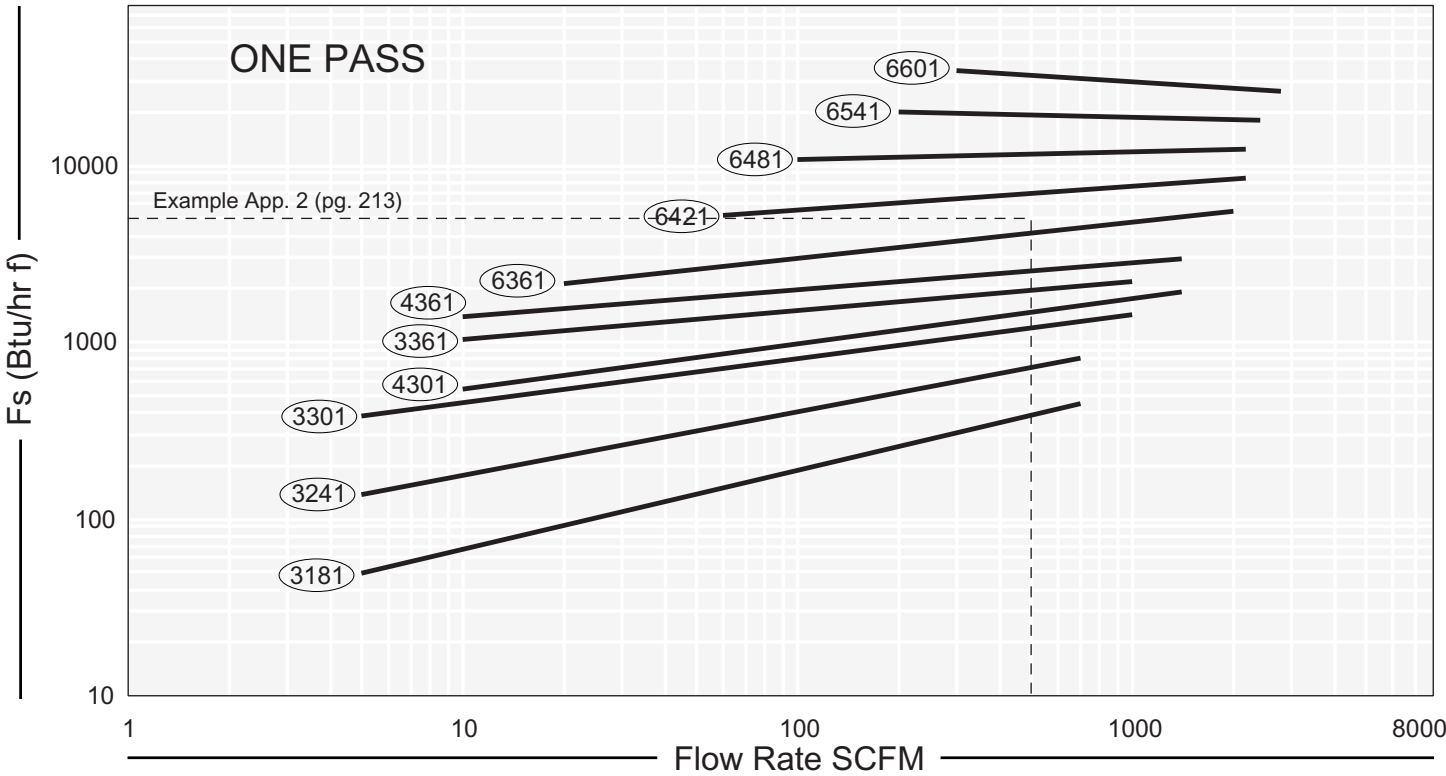

Example

Application #3 (p.5)

SCFM = 76

ΔPSI required = 5" H₂O

Model selection = ACA-6421-3

F_s = 1,288 Nozzle check (p.4) = 3.10 or 3"NPT

$$F_s = \frac{\text{Heat Load (Btu/hr)}}{\text{Process exiting temperature } (T_2) - \text{Ambient air entering the cooler } (T_a) \text{ from cooler}}$$

note: AIHTI reserves the right to make reasonable design changes without notice.

ACA Series dimensions

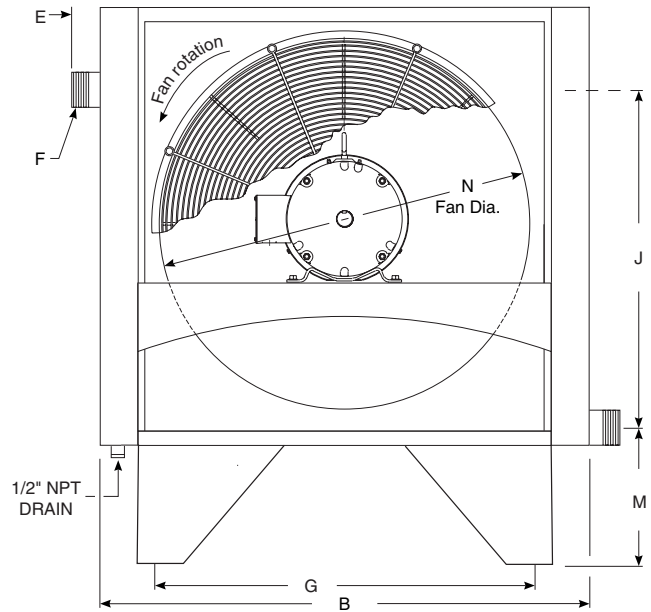
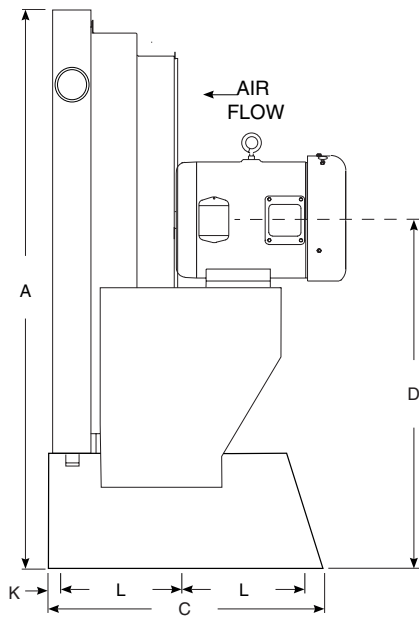

ACA - 3181 through ACA - 4361

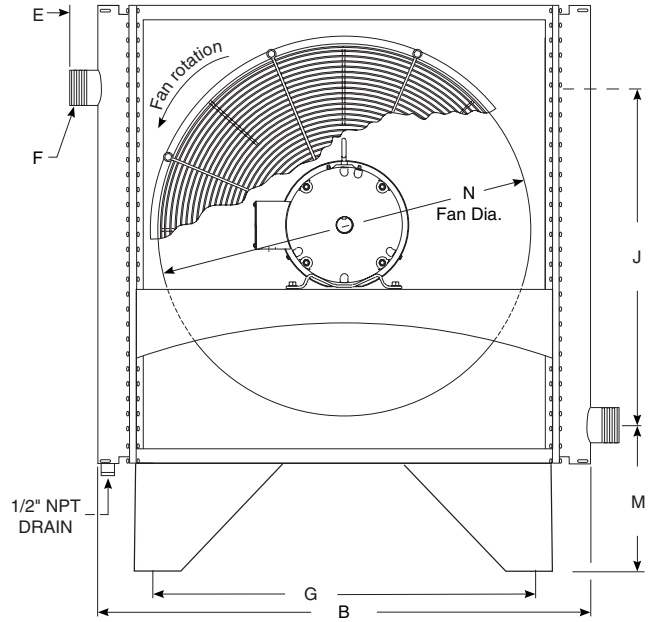
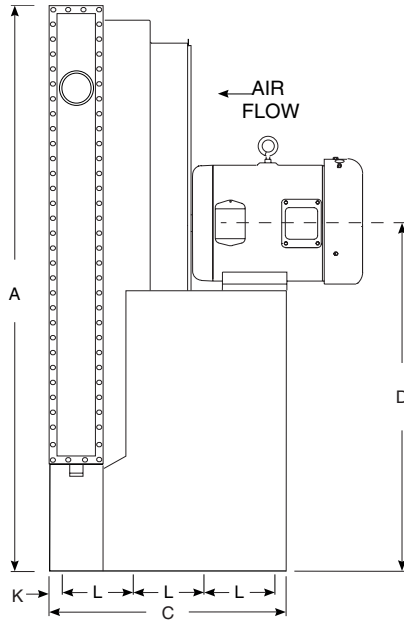

ACA - 6301 through ACA - 6601

DIMENSIONS (inches)												
Model	A	B	C	D	E	F NPT	G	J	K	L	M	N
ACA - 3181	30.6	23.0	19.8	20.25	2.5	1.5	16.3	12.98	1.5	8.38	11.93	14.0
ACA - 3241	36.6	29.0	19.8	23.25	2.5	1.5	22.3	17.48	1.5	8.38	11.93	22.0
ACA - 3301	42.6	35.0	19.8	26.25	2.5	2.0	28.3	21.75	1.5	8.38	12.15	28.0
ACA - 4301	42.6	36.0	19.8	26.25	2.5	2.5	28.3	21.55	1.5	8.38	12.35	28.0
ACA - 6301	42.6	38.8	19.8	26.25	2.5	3.0	28.3	21.07	1.5	8.38	12.98	28.0
ACA - 3361	48.6	41.0	19.8	29.25	2.5	2.0	34.3	26.25	1.5	8.38	12.15	32.0
ACA - 4361	48.6	42.0	19.8	29.25	2.5	2.5	34.4	26.05	1.5	8.38	12.35	32.0
ACA - 6361	48.5	43.9	19.8	29.25	2.5	3.0	34.3	26.0	1.5	8.38	12.7	32.0
ACA - 6421	54.5	50.8	27.36	32.25	2.5	4.0	40.3	29.4	2.0	6.75	13.3	36.0
ACA - 6481	60.6	56.8	27.36	35.25	2.5	4.0	46.3	34.1	2.0	6.75	13.3	42.0
ACA - 6541	66.6	62.8	28.83	38.25	2.5	4.0	52.3	38.6	2.0	6.75	13.3	48.0
ACA - 6601	72.4	67.9	30.6	41.25	2.5	4.0	58.3	43.05	2.0	6.75	13.3	48.0

note: AIHTI reserves the right to make reasonable design changes without notice.

ACA Series *dimensions*

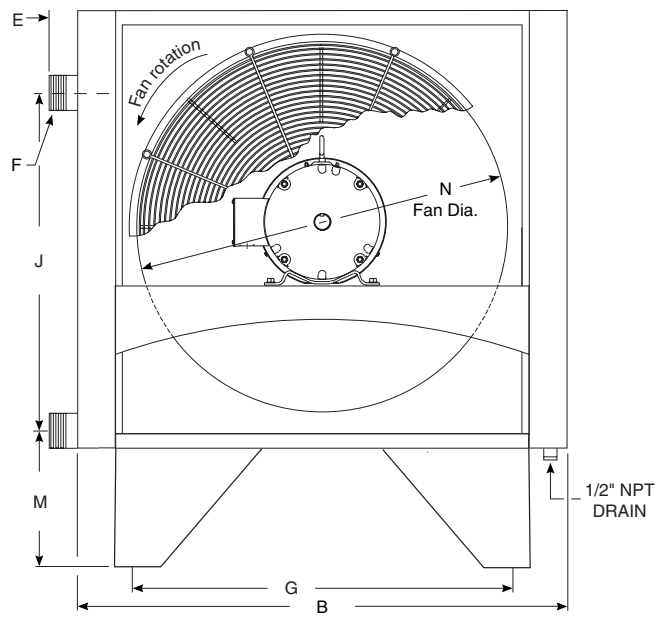
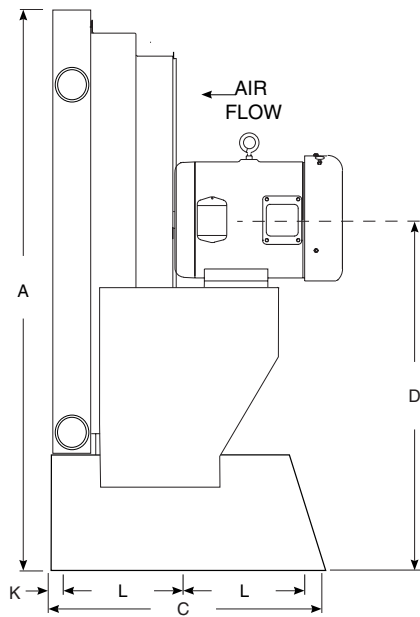

ACA - 3182 through ACA - 4362

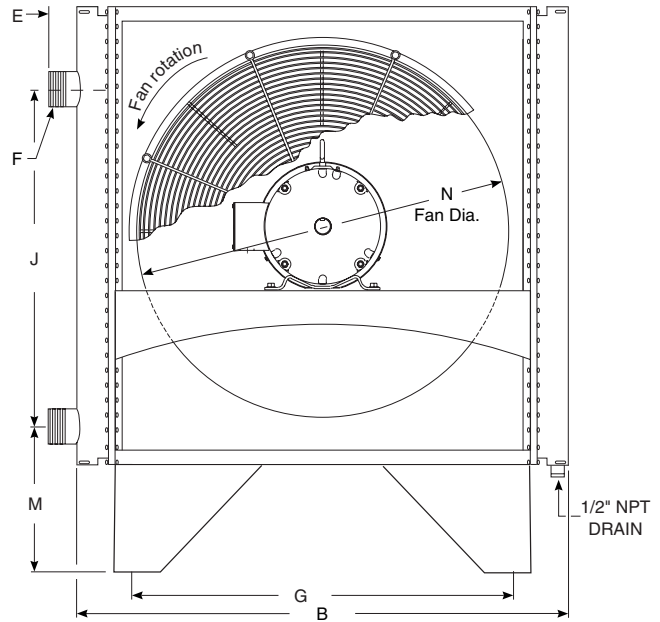
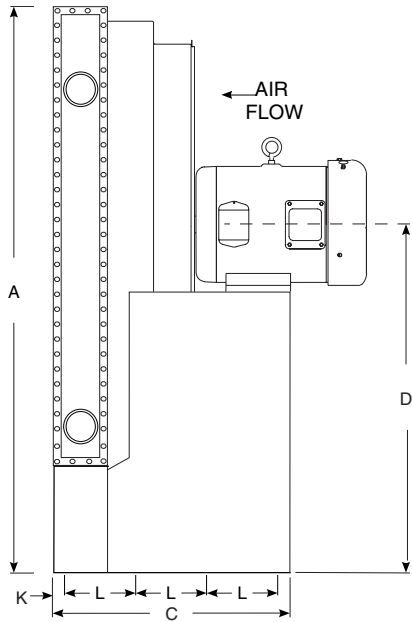

ACA - 6302 through ACA - 6602

DIMENSIONS (inches)												
Model	A	B	C	D	E	F NPT	G	J	K	L	M	N
ACA - 3182	30.6	23.0	19.8	20.25	2.5	1.5	16.3	12.98	1.5	8.38	11.93	14.0
ACA - 3242	36.6	29.0	19.8	23.25	2.5	1.5	22.3	17.48	1.5	8.38	11.93	22.0
ACA - 3302	42.6	35.0	19.8	26.25	2.5	2.0	28.3	21.75	1.5	8.38	12.15	28.0
ACA - 4302	42.6	36.0	19.8	26.25	2.5	2.5	28.3	21.55	1.5	8.38	12.35	28.0
ACA - 6302	42.6	38.8	19.8	26.25	2.5	3.0	28.3	21.07	1.5	8.38	12.98	28.0
ACA - 3362	48.6	41.0	19.8	29.25	2.5	2.0	34.3	26.25	1.5	8.38	12.15	32.0
ACA - 4362	48.6	42.0	19.8	29.25	2.5	2.5	34.4	26.05	1.5	8.38	12.35	32.0
ACA - 6362	48.5	43.9	19.8	29.25	2.5	3.0	34.3	26.0	1.5	8.38	12.7	32.0
ACA - 6422	54.5	50.8	27.36	32.25	2.5	4.0	40.3	29.4	2.0	6.75	13.3	36.0
ACA - 6482	60.6	56.8	27.36	35.25	2.5	4.0	46.3	34.1	2.0	6.75	13.3	42.0
ACA - 6542	66.6	62.8	28.83	38.25	2.5	4.0	52.3	38.6	2.0	6.75	13.3	48.0
ACA - 6602	72.4	67.9	30.6	41.25	2.5	4.0	58.3	43.05	2.0	6.75	13.3	48.0

note: AIHTI reserves the right to make reasonable design changes without notice.

ACA Series motor data

ELECTRIC MOTOR DATA

Model	Horse Power	Phase	Hz	Volts	RPM	NEMA Frame	Enclosure Type	Full Load Amperes	Service Factor	Thermal Overload
ACA- 3181/2- 1	.25	1	60-50	115/230 - 90/190	1725-1440	48	TEFC	3.2/1.6/2.8-1.4	1.15	NO
ACA- 3181/2 -3	.25	3	60-50	208 - 230/460 - 190/380	1725-1440	48	TEFC	1.3/.65/1.1-.55	1.15	NO
ACA- 3241/2 -1	.25	1	60-50	115/230 - 90/190	1140-950	56	TEFC	6.8/3.1-3.4	1.15	NO
ACA- 3241/2 -3	.25	3	60-50	208 - 230/460 - 190/380	1140-950	56	TEFC	1.7/2.0/1.0	1.15	NO
ACA- 3301/2 -1	.5	1	60-50	115/230 - 90/190	1140-950	56	TEFC	9.6/4.7-4.8/10.4/5.2	1.15	NO
ACA- 3301/2 -3	.5	3	60-50	208 - 230/460 - 190/380	1140-950	56	TEFC	2.4-2.7/1.35-2.5/1.25	1.15	NO
ACA- 4301/2 -1	.5	1	60-50	115/230 - 90/190	1140-950	56	TEFC	9.6/4.7-4.8/10.4/5.2	1.15	NO
ACA- 4301/2 -3	.5	3	60-50	208 - 230/460 - 190/380	1140-950	56	TEFC	2.4-2.7/1.35-2.5/1.25	1.15	NO
ACA- 6301/2 -3	1.0	3	60-50	208 - 230/460 - 190/380	1140-950	56	TEFC	4/2-3.7/1.85	1.15	NO
ACA- 3361/2 -3	1.0	3	60-50	208 - 230/460 - 190/380	1140-950	56	TEFC	4/2-3.7/1.85	1.15	NO
ACA- 4361/2- 3	1.0	3	60-50	208 - 230/460 - 190/380	1140-950	56	TEFC	4/2-3.7/1.85	1.15	NO
ACA- 6361/2 -3	3.0	3	60-50	208 - 230/460 - 190/380	1725-1440	182T	TEFC	8.4-6.8/3.4	1.15	NO
ACA- 6421/2 -3	5.0	3	60-50	208 - 230/460 - 190/380	1140-950	213T	TEFC	8.2-7.6/3.8	1.15	NO
ACA- 6481/2 -3	5.0	3	60-50	208 - 230/460 - 190/380	1140-950	213T	TEFC	14.0/7.0	1.15	NO
ACA- 6541/2 -3	7.5	3	60-50	208 - 230/460 - 190/380	1140-950	254T	TEFC	20.4/10.2	1.15	NO
ACA- 6601/2 -3	10	3	60-50	208 - 230/460 - 190/380	1140-950	256T	TEFC	28.0/14.0	1.15	NO

ELECTRIC MOTOR NOTES:

- Motor electrical ratings are an approximate guide and may vary between motor manufacturers. Consult ratings on motor data plate prior to installation and operation.
- Explosion proof, high temperature, severe duty, chemical, IEC, Canadian Standards Association, and Underwriters Laboratory recognized motors are available upon request.
- American Industrial reserves the right to enact changes to motor brand, type and ratings regarding horsepower, RPM,FLA,and service factor for standard products without notice. All specific requirements will be honored without change.
- Fan rotation is clockwise when facing the motor shaft.
- The above motors contain factory lubricated shielded ball bearings (no additional lubrication is required).
- Abbreviation Index**
TEFC.....Totally Enclosed, Fan Cooled
EXP.....Explosion Proof

CLASS I,DIV.1, GROUP D or CLASS II,DIV.2, GROUP F & G EXPLOSION PROOF MOTOR DATA

Model	Horse Power	Phase	Hz	Volts	RPM	NEMA Frame	Enclosure Type	Full Load Amperes	Service Factor	Thermal Overload
ACA- 3181/2 -1	.25	1	60	115/230	1725	48	EXP	5.8/2.8	1.0	YES
ACA- 3181/2 -3	.25	3	60	208-230/460	1725	48	EXP	1.4-1.3/.65	1.0	YES
ACA- 3241/2 -3	.33	1	60	115/230	1140	56	EXP	7.8/3.5	1.0	YES
ACA- 3241/2 -1	.33	3	60	208-230/460	1140	56	EXP	1.18-1.6/8	1.0	YES
ACA- 3301/2 -3	.75	1	60	115/230	1140	56	EXP	9.4/4.8	1.0	YES
ACA- 3301/2 -1	.75	3	60	208-230/460	1140	56	EXP	2.5-2.4/1.2	1.0	YES
ACA- 4301/2 -3	.75	1	60	115/230	1140	56	EXP	9.4/4.8	1.0	YES
ACA- 4301/2 -1	.75	3	60	208-230/460	1140	56	EXP	2.5-2.4/1.2	1.0	YES
ACA- 6301/2 -1	1.0	3	60	230/460	1140	56	EXP	3.8/1.9	1.0	YES
ACA- 3361/2 -3	1.0	3	60	230/460	1140	56	EXP	3.8/1.9	1.0	YES
ACA- 4361/2 -3	1.0	3	60	230/460	1140	56	EXP	3.8/1.9	1.15	YES
ACA- 6361/2 -3	3	3	60	230/460	1725	182	EXP	8.8/4.4	1.15	YES
ACA- 6421/2 -3	5	3	60	230/460	1160	215	EXP	15.0-13.8/6.9	1.15	YES
ACA- 6481/2 -3	5	3	60	230/460	1160	215	EXP	15.0-13.8/6.9	1.15	YES
ACA- 6541/2 -3	7.5	3	60	230/460	1160	256	EXP	21.6-20.4/10.2	1.15	YES
ACA- 6601/2 -3	10	3	60	230/460	1160	256	EXP	29-26/13	1.15	YES

NOTE: Basic electric drive units are supplied with one of the corresponding above listed motors.

575 VOLT ELECTRIC MOTOR DATA

Model	Horse Power	Phase	Hz	Volts	RPM	NEMA Frame	Enclosure Type	Full Load Amperes	Service Factor	Thermal Overload
ACA-3181/2 -5	1/3	3	60	575	1725	56	TEFC	.52 .56	1.15	NO
ACA-3241/2 -5	1/3	3	60	575	1140	56	TEFC	.52 .56	1.15	NO
ACA-3301/2 -5	1/2	3	60	575	1140	56	TEFC	1.08	1.15	NO
ACA-4301/2 -5	1/2	3	60	575	1140	56	TEFC	1.08	1.15	NO
ACA-6301/2 -5	1	3	60	575	1140	56	TEFC	1.6	1.15	NO
ACA-3361/2 -5	1	3	60	575	1140	56	TEFC	1.6	1.15	NO
ACA-4361/2 -5	1	3	60	575	1140	56	TEFC	1.6	1.15	NO
ACA-6361/2 -5	3	3	60	575	1725	182T	TEFC	3.3	1.15	NO
ACA-6421/2 -5	5	3	60	575	1140	213T	TEFC	5.9	1.15	NO
ACA-6481/2 -5	5	3	60	575	1140	213T	TEFC	5.9	1.15	NO
ACA-6541/2 -5	7.5	3	60	575	1140	254T	TEFC	8.0	1.15	NO
ACA-6601/2 -5	10	3	60	575	1140	256T	TEFC	10.5	1.15	NO

COMMON DATA

Model	Air Flow		Sound Level dB(A) @ 7ft	Weight		Serviceable Core
	CFM	m³/s		w/ motor	w/o motor	
ACA-3181/2	1550	0.731	72	131	111	NO
ACA-3241/2	2900	1.36	76	154	134	NO
ACA-3301/2	4450	2.10	76	184	160	NO
ACA-4301/2	4450	2.10	76	211	187	NO
ACA-6301/2	4450	2.10	76	343	305	YES
ACA-3361/2	6350	2.99	79	243	205	NO
ACA-4361/2	6350	2.99	79	289	251	NO
ACA-6361/2	10500	4.95	91	402	342	YES
ACA-6421/2	14300	6.75	87	636	443	YES
ACA-6481/2	18700	8.82	88	753	560	YES
ACA-6541/2	23350	11.02	91	938	691	YES
ACA-6601/2	29300	13.83	91	1104	835	YES

NOTES:

TEFC = Totally Enclosed, Fan Cooled

To estimate the sound level at distances other than 7 feet (2.1 meters) from the cooler, add 6 db for each halving of distance, or subtract 6 db for each doubling of the distance.

Example:

The Sound Level of the ACA-3181/2 is 72 dB at 7ft. At 3.5ft (7ft x 0.5 = 3.5ft) the sound level is 66 dB (72dB - 6dB = 66dB). At 14ft (7ft x 2 = 14ft) the sound level is 78dB (72dB + 6dB = 78dB).

Pressure Drop Graphs (see page 220)

Each graph represents a specific pressure drop at differing flow rates and inlet pressures. The four graphs for each model series size represents the more popular milestone pressure differentials commonly applied.

To use the graphs for selection purposes follow the steps below.

- 1) Locate the operating pressure at the bottom of the desired pressure drop chart.
- 2) Locate the flow rate in SCFM at the left end of the chart.
- 3) Follow the "Pressure" line vertically and the "Flow" line horizontally until they cross, note the location.
- 4) The curve on, or closest above will be exact or less pressure drop than requested and suitable for the application.
- 5) There may be several units shown above the intersection point, all of which will produce less than the desired pressure drop at the required flow.

Example: Application 3 Low Pressure Blower

Flow = 76 SCFM

Operating pressure = 2 PSIG

Initial selection from graph page 215 = ACA-3302

Desired pressure drop = 5" H₂O or less. (USE the "Pressure Drop 5" H₂O" curves page 220)

From the pressure drop graph, page 220. Acceptable choice - ACA-3302 is on the line, ACA-3242 is well below the line. The ACA-3302 meets the pressure drop requirement, but exceeds the capacity requirement. However, even though the ACA-3242 exceeds 5" of water pressure drop, other considerations should be made prior to selection such as unit physical size, cost, availability, and port size.

ACA Series pressure drop graphs

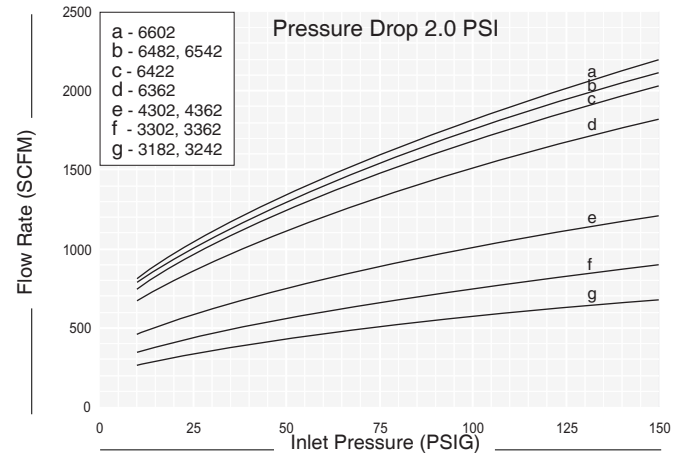
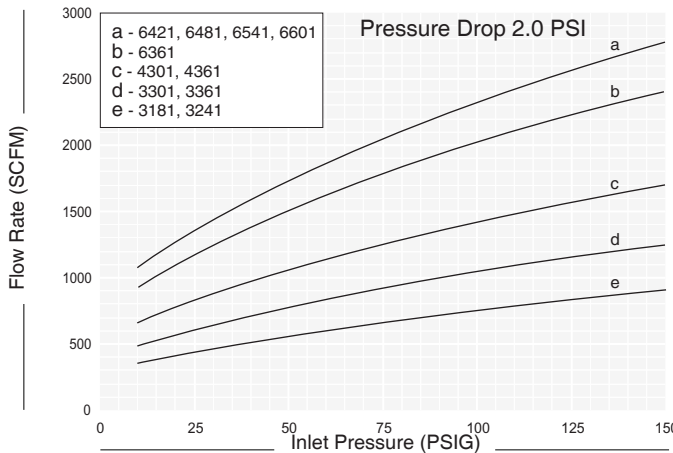
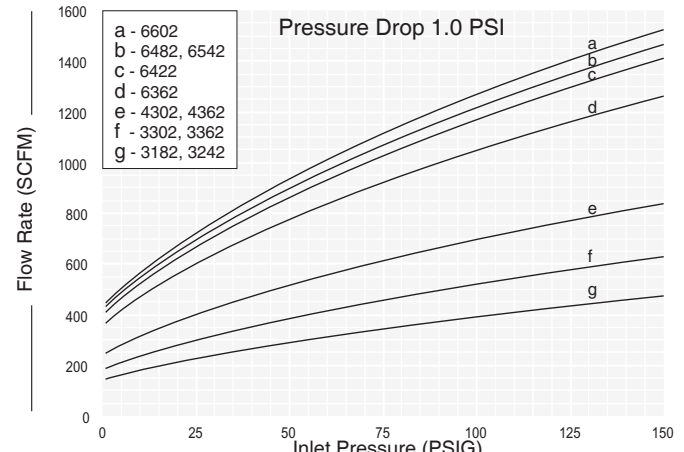
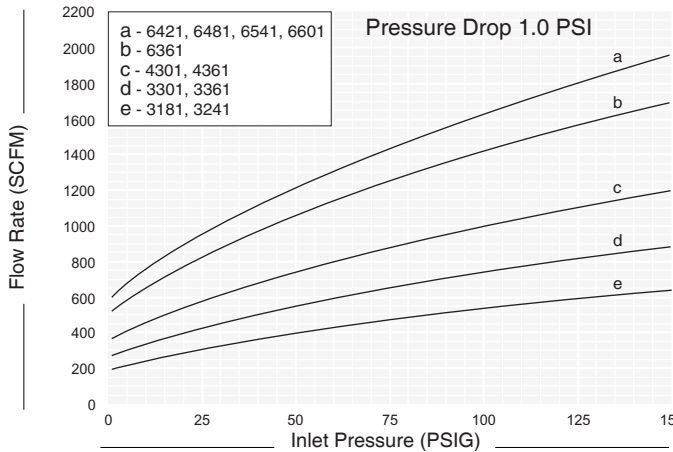
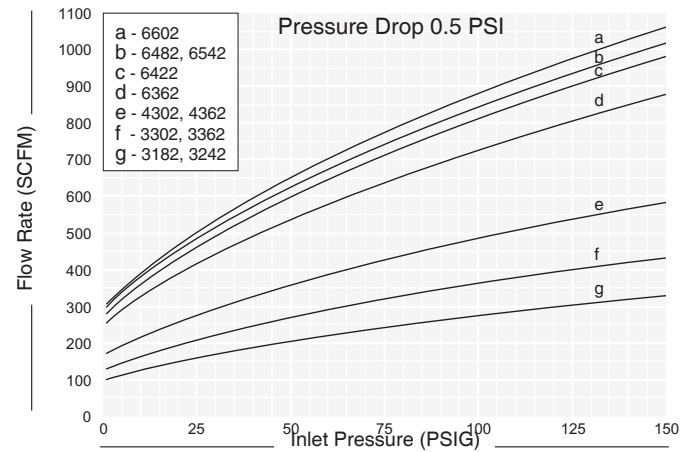
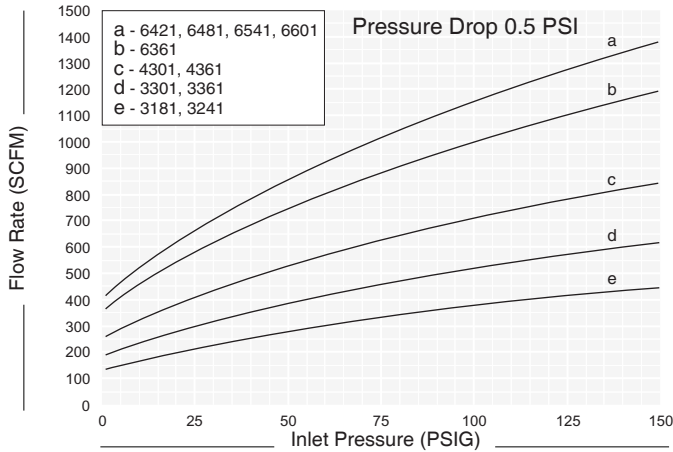
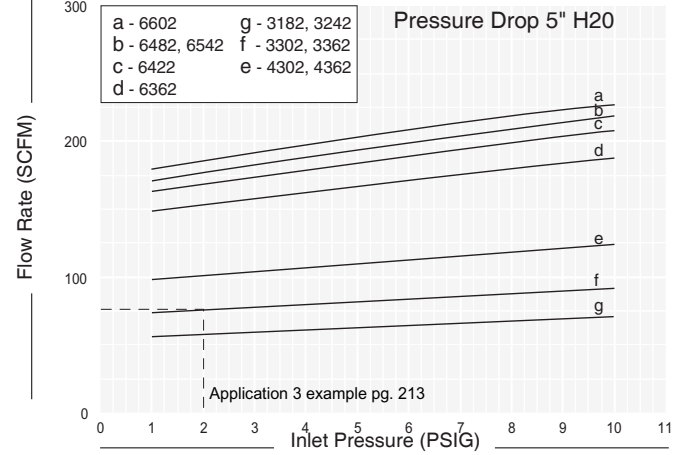
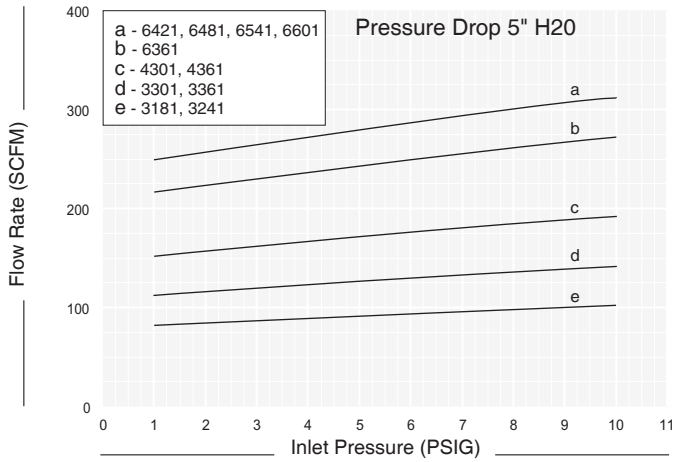

note: AIHTI reserves the right to make reasonable design changes without notice.

PIPING HOOK UP

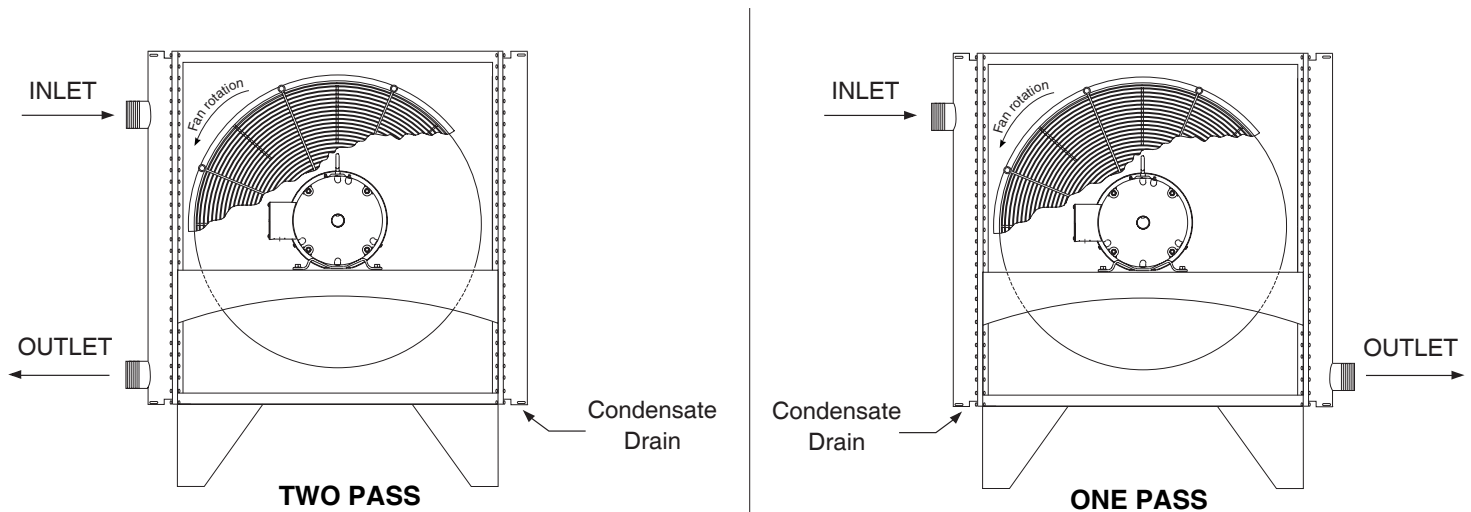

Receiving:

a) Inspect unit for any shipping damage before uncrating. Indicate all damages to the trucking firms' delivery person and mark it on the receiving bill before accepting the freight. Make sure that the core and fan are not damaged. Rotate the fan blade to make sure that it moves freely. The published weight information located in this brochure is approximate. True shipment weights are determined at the time of shipping and may vary. Approximate weight information published herein is for engineering approximation purposes and should not be used for exact shipping weight. *Since the warranty is based upon the unit date code located on the model identification tag, removal or manipulation of the identification tag will void the manufacturers warranty.*

b) When handling the ACA heat exchanger, special care should be taken to avoid damage to the core and fan. All units are shipped with wood skids for easy forklift handling

c) Standard Enamel Coating: American Industrial provides its standard products with a normal base coat of oil base air cure enamel paint. The enamel paint is applied as a temporary protective and esthetic coating prior to shipment. While the standard enamel coating is durable, American Industrial does not warrant it as a long-term finish coating. It is strongly suggested that a more durable final coating be applied after installation or prior to long-term storage in a corrosive environment to cover any accidental scratches, enhance esthetics, and further prevent corrosion. It is the responsibility of the customer to provide regular maintenance against chips, scratches, etc... and regular touch up maintenance must be provided for long-term benefits and corrosion prevention.

Installation:

a) American Industrial recommends that the equipment supplied should be installed by qualified personal who have solid understanding of system design, pressure and temperature ratings, and piping assembly. Verify the service conditions of the system prior to applying any ACA series cooler. If the system pressure or temperature does not fall within the parameters on ACA rat-

ing tag located on the heat exchanger, contact our factory prior to installation or operation.

b) In order for the heat exchanger to properly function, installation should be made with minimum airflow obstruction distance of not less than twenty (20) inches on both fan intake and exiting side of the heat exchanger.

c) Process piping should be as indicated above with the process flow entering into the upper port and exiting out the lower port (see illustration). This configuration will allow for condensate moisture to drain completely from the equipment. It is recommended that an air separator or automatic drip leg be applied to the outlet side of the heat exchanger to trap any moisture that develops.

d) Flow line sizes should be sized to handle the appropriate flow to meet the system pressure drop requirements. If the nozzle size of the heat exchanger is smaller than the process line size an increased pressure differential at the heat exchanger may occur.

e) ACA series coolers are produced with both brazed ACA-3181 through ACA-4362, and serviceable core® ACA-6301 through ACA-6602 style coils. A brazed construction coil does not allow internal tube access. A serviceable core® will allow full accessibility to the internal tubes for cleaning and maintenance. ACA series coolers are rated for 150 PSIG working pressure, and a 400°f working temperature.

f) Special Coatings: American Industrial offers as customer options, Air-Dry Epoxy, and Heresite (Air-Dry Phenolic) coatings at additional cost. American Industrial offers special coatings upon request, however American Industrial does not warrant coatings to be a permanent solution for any equipment against corrosion. It is the responsibility of the customer to provide regular maintenance against chips, scratches, etc... and regular touch up maintenance must be provided for long-term benefits and corrosion prevention.

ACA Series *installation & maintenance*

g) Electric motors should be connected only to supply source of the same characteristics as indicated on the electric motor information plate. Prior to starting, verify that the motor and fan spin freely without obstruction. Check carefully that the fan turns in the correct rotation direction normally counter clockwise from the motor side (fan direction arrow). Failure to operate the fan in the proper direction could reduce performance or cause serious damage to the heat exchanger or other components. Fan blades should be rechecked for tightness after the first 100 hours of operation.

Maintenance

Regular maintenance intervals based upon the surrounding and operational conditions should be maintained to verify equipment performance and to prevent premature component failure. Since some of the components such as, motors, fans, load adapters, etc... are not manufactured by American Industrial maintenance requirements provided by the manufacture must be followed.

a) Inspect the entire heat exchanger and motor/fan assembly for loosened bolts, loose connections, broken components, rust spots, corrosion, fin/coil clogging, or external leakage. Make immediate repairs to all affected areas prior to restarting and operating the heat exchanger or its components.

b) Heat exchangers operating in oily or dusty environments will often need to have the coil cooling fins cleaned. Oily or clogged fins should be cleaned by carefully brushing the fins and tubes with water or a non-aggressive degreasing agent mixture (Note: Cleaning agents that are not compatible with copper, brass, aluminum, steel or stainless steel should not be used). A compressed air or a water stream can be used to dislodge dirt and clean the coil further. Any external dirt or oil on the electric motor and fan assembly should be removed. Caution: Be sure to disconnect the electric motor from its power source prior to doing any maintenance.

c) In most cases it is not necessary to internally flush the coil. In circumstances where the coil has become plugged or has a substantial buildup of material, flushing the coil with water or a solvent may be done. Flushing solvents should be non-aggressive suitable for the materials of construction. Serviceable Core® models can be disassembled and inspected or cleaned if required.

d) Most low horsepower electric motors do not require any additional lubrication. However, larger motors must be lubricated with good quality grease as specified by the manufacture at least once every 6-9 months or as directed by the manufacture. T.E.F.C. air ventilation slots should be inspected and cleaned regularly to prevent clogging and starving the motor of cooling air. To maintain the electric motor properly see the manufactures requirements and specifications.

e) Fan blades should be cleaned and inspected for tightness during the regular maintenance schedule when handling a fan blade care must be given to avoid bending or striking any of the blades. Fan blades are factory balanced and will not operate properly if damaged or unbalanced. Damaged fan blades can cause excessive vibration and severe damage to the heat exchanger or drive motor.

Replace any damaged fan with an American industrial suggested replacement.

f) ACA heat exchanger cabinets are constructed using 7ga. through 18ga. steel that may be bent back into position if damaged. Parts that are not repairable can be purchased through American Industrial.

g) Coil fins that become flattened can be combed back into position. This process may require removal of the coil from the cabinet.

h) It is not advisable to attempt repairs to brazed joints of a brazed construction coil unless it will be done by an expert in silver solder brazing. Brazed coils are heated uniformly during the original manufacturing process to prevent weak zones from occurring. Uncontrolled reheating of the coil may result in weakening of the tube joints surrounding the repair area. In many instances brazed units that are repaired will not hold up as well to the rigors of the system as will a new coil. American Industrial will not warranty or be responsible for any repairs done by unauthorized sources. Manipulation in any way other than normal application will void the manufactures warranty.

i) Units containing a Serviceable Core® have bolted manifold covers that can be removed for cleaning or repair purposes.

Service Sequence

American Industrial has gone to great lengths to provide components that are repairable. If the ACA unit requires internal cleaning or attention the following steps will explain what must be done to access the internal tubes. Be sure to order gasket kits or repair parts prior to removal and disassembly to minimize down time.

a) To clean the internal tubes first remove all connection pipes from the unit.

b) Be sure the unit is drained of all water etc...

c) Place the ACA unit in an area that it can be accessed from all sides.

d) Remove the manifold cover bolts and hardware and place them into a secure place.

e) The manifold covers are tightly compressed and may need some prying to separate them from the gasket, physically remove the cover assemblies from both sides.

f) The tubes are now accessible for cleaning. We suggest a mild water-soluble degreaser be used with a brush. Tubing I.D. is .325 a plastic bristle brush on a rod will work best for cleaning the tubes. Steel brushes should be avoided since the steel is harder than the copper tubing and may heavily score the tubes if used.

g) If there are any leaking tubes you may plug them by forcing a soft metal plug into the hole and tapping it tight. You may in some cases weld the leaking tube shut however, care should be taken since excessive heat may cause surrounding tube joints to loosen and leak.